

QUARTER CIRCLE LA RANCH NEIGHBORHOOD PLAN



MAY 2005

Prepared by: **Thomas, Dean & Hoskins, Inc.**
31 Three Mile Drive, Suite 101
Kalispell, MT 59901
Phone: (406) 751-5246 • Fax (406) 752-5230



EXECUTIVE SUMMARY

QUARTER CIRCLE RANCH NEIGHBORHOOD PLAN

Current Growth Policy designation is “Agricultural”:

- ◆ The 800 acres of the Neighborhood Plan are designated as agricultural in the Bigfork Land Use Plan (BFLUP)
- ◆ There are approximately 26,960 acres designated agricultural in the entire BFLUP area
- ◆ Lands in the Neighborhood Plan are zoned Suburban Agricultural 5 acre, SAG-5, minimum lot size
- ◆ Lands in the Plan area are currently in tract sizes of 20 to 240 acres
- ◆ BFLUP encourages preservation of productive agricultural lands
- ◆ The Plan area lands are not productive. Lands are suitable for limited timber production
- ◆ Current land use designation and zoning encourages scattered development
- ◆ Scattered development is natural resource consumptive
- ◆ Scattered development does not encourage preservation
- ◆ Scattered development encourages urban sprawl
- ◆ Scattered development does not consider land form features
- ◆ Scattered development does not consider infrastructure impacts
- ◆ Scattered development does not build community oriented neighborhoods
- ◆ Scattered development will not compliment the Bigfork community
- ◆ Scattered development does not provide community recreational amenities

The Quarter Circle Ranch Neighborhood Plan:

- ◆ Maintains the character of the agricultural land use designation
- ◆ Maintains the character of the SAG-5 zoning
- ◆ Will require clustered development;
- ◆ Encourages preservation of the natural resources;
- ◆ Limits the impact to the environment;
- ◆ Prohibits urban sprawl;
- ◆ Preserves and protects the land forms;
- ◆ Minimizes infrastructure impacts;
- ◆ Directs infrastructure needs to public entities;
- ◆ Establishes a comprehensive development theme;
- ◆ Plans for a high quality residential environment with extensive equestrian facilities and water-based recreation;
- ◆ Plans for long-term management of amenities, maintenance and operations
- ◆ Creates a community complimenting the Flathead Lake Lodge and Bigfork community
- ◆ Establishes a plan to financially support the Bigfork Community Foundations
- ◆ Is a plan to combine ownership of two different adjoining properties to unite them under one unique Western-style theme
- ◆ Creates a sense of cultural and environmental stewardship

The proposed neighborhood plan will provide the basis for future land use decisions supporting the Goals and Objectives of the Bigfork Land Use Plan. Implementation of the neighborhood plan



will be for limited development in a sensitive area near the community of Bigfork, while preserving the character of the planning area. The character will be preserved through stewardship of the land forms

demonstrated by clustering, preservation of open space, encouraging the use of common infrastructure, rustic architectural themes and community participation.

This neighborhood plan is the culmination of years of planning towards the unique mountain lodge concept. The property has been under the same family ownership for 60 years. Quarter Circle LA Ranches at the Ranch is the parent corporation, DBA Flathead Lake Lodge. The mountain land has been used extensively and exclusively by the Lodge for scenic horseback rides, overnight camps,

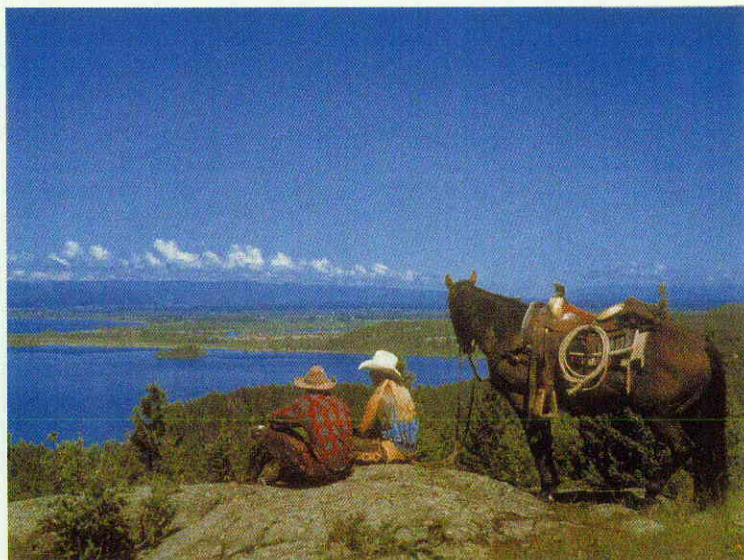

wedding sites, BBQ's, breakfast and lunch rides, outdoor educational tours, and a multitude of recreational uses. It has been extensively managed for timber using the latest and best management practices. The Ranch has taken the lead in environmental and stewardship logging using Swedish high tech logging equipment to minimize land impacts. The land is managed for disease, weeds, infestations, re-growth, wildlife and fire management. The plan will create an unpretentious, laid back family-oriented community which facilitates the enjoyment of a wide variety of outdoor activities. It will be an enhancing element to the community of Bigfork, not only economically, but also in the way it is developed and operated. The opportunity exists to create a special community which uses activities and programming to create a culture and sense of togetherness which does not exist elsewhere.

Environmental stewardship and sound conservation practices have and will be themes throughout the development process and be instilled as an essential part of the community culture.

The theme would be early Western Pioneer Architecture utilizing logs, hand hewn effects, native rocks, lower rooflines, larger porches, less reflective glass, natural colors, controlled down lighting and numerous characteristics of early west with exquisite style and quality. The concept limits building sites and sizes, attempting to create simple elegance. The concept is highly planned and designed for family interaction. The plan is based on expanding the formula that has made Flathead Lake Lodge, Montana's top rated facility, eighteen consecutive years, and rated the top 2% best places in America.

Clustering of development in a western village theme will create an environment of interaction among neighbors, which is difficult to accomplish with traditional development. Clustering will create mountain villages which provide a natural amenity with trails, privacy and undisturbed forest ecosystems.



QUARTER CIRCLE RANCH NEIGHBORHOOD PLAN NARRATIVE

1. Introduction

The area of the Plan Amendment request is 800 acres, as shown on the attached Figure 1. Approximately 640 acres comprise a single contiguous tract, on which the anticipated development will occur. Another 160 acres within the adjoining lands owned by Quarter Circle are designated as being set aside as perimeter buffering and sensitive environmental areas which will remain as open space as part of the plan. Currently the lands are designated as agricultural



under the Flathead County Growth Policy and Bigfork Land Use Plan (BFLUP). Agricultural lands policy can be summarized by paragraph 1.7 of the BFLUP, “Important productive farm lands which are not in the urban growth area of a city which are not served

by community sewer or water systems and which are not already excessively impacted by existing or impending development should be preserved”. Zoning Sag-5 is defined as “A district to provide and preserve smaller agricultural functions and to provide a buffer between urban and unlimited agricultural uses in areas where potential conflict of uses will be minimized and to provide areas of estate residential development”. The lands subject to this application are not productive agricultural lands. These lands do provide a buffer between the urbanized area of Bigfork and National Forest. The lands, as will be demonstrated later, are not suited for estate type development when evaluated according to the

Goals and Policies of the BFLUP. An amendment to the BFLUP is proposed to change the plan and plan map by defining a unique development scope and intensity of land use, which complies with the BFLUP.

Quarter Circle Ranch Neighborhood Plan (QCR) will establish the goals and policies for a western-themed equestrian community with an emphasis on environmental and conservation practices. The overall theme will blend the natural environment, resource conservation and social interaction in an early 19th century motif. The management would be patterned after the very successful Flathead Lake Lodge model, established by the Averill's in 1945, a complete recreational community with first class accommodations with a rustic Montana setting.

The Site

Located directly south of the Swan River and the village of Bigfork, are the 800 acres, a hilly site with a wide variety of topography. The entire area is timbered. There are no distinct stream or surface water features. The northerly most 240 acres, presently under contract, has not been managed under the same timber program, and is infected with mistletoe, a tree fungus characteristic of the East Shore of Flathead Lake. This land is under contract and will be included in the same stewardship practices as the remaining Ranch land, which has been highly managed for timber for decades. The timber management plan includes ongoing fire reduction, growing sustainable timber, and controlling weeds and disease. The timber prescription is thinned in



mosaic patterns of 3-5 acre areas to give the impression of a natural forest. There are three levels of thinning on the Ranch's 2000 acres and within the proposed Neighborhood Plan area. Thinning utilizes the Swedish Timber Jack, state of the art equipment, which is designed for low impact to the land. The Averill's operate one of only a few of these machines in Montana. The land is presently thinned to three different levels:

1. Fire safe level: large spacing appearing meadow-like;
2. Fire reduction level: spacing of timber 20'-30' with removal of lower ladder fuels;
3. Park style level thinning: 15'-20' spacing, leaving larger trees. All three levels are aesthetically pleasing. When each is complete, the area is cleaned and reseeded with wilderness grass mix.

Recreational amenities will include an expansive equestrian center designed in a pioneer theme utilizing historic hand hewn dovetail buildings. The land will have numerous equestrian trails, hiking, biking, and jogging paths, cross-country ski trails, ice skating ponds, fish ponds, tennis courts, pool, trappers cabin outposts, educational sites, rock overlooks, fire tower, and numerous other recreational facilities. The main lodge will be a focal point of



interaction. The facility will include a full service off-site marina in Woods Bay to accommodate boating enthusiasts who are occupants of the Neighborhood Planned Area as well as valley residents.

The site proposed for the QCR plan currently provides an undisturbed view shed for the Bigfork community. Figure 2 shows the slopes, which are visible from the Bigfork area. Development goals of the plan will preserve this important view shed for the community.

Topography within the site varies with a number of valleys and ridges. Elevation change is the greatest from the entrance on



Highway 209, approximately 150 vertical feet in a straight line distance of $\frac{1}{4}$ mile. The highest elevation in the community is 500 feet higher but occurs a mile to the east. From east to west there are five defined ridge and valley complexes.

Ground slopes vary, with many select areas having slopes less than 15%. A number of these areas would be developed in the future with cluster housing.

Currently the entire 800 acres is zoned SAG-5, a zone providing for a minimum lot size of five acres. A total of 160 lots could be subdivided under current zoning using a conventional Euclidean approach for the lots. A conventional approach would not recognize the significance of the site as the Bigfork view shed and result in the permanent loss of this component to Bigfork's character. An alternative approach is to develop a plan which recognizes the unique character of the site, offers a wide variety of residential opportunities and preserves the natural features.

Preservation is best accomplished in a development scenario by clustering housing units and thereby maintaining large areas as open space, or undeveloped area. Preservation is also enhanced through stewardship, managing the resources.

The Plan

As proposed, the neighborhood plan envisions 319 residential units clustered in sites appropriate for development, a social/equestrian area, lodge and lodge annexes, cluster cabins, cabins and single family lots. Recreational amenities will include equestrian trails, cross-country ski trails, ice skating, tennis courts and a pool. Cluster cabins, cabins and single family lots would be planned for specific areas. Housing types would not be mixed in an area. Each residential area would have a center for neighborhood gatherings and interaction.

The Neighborhood Plan is intended to outline more than a resort or residential development; it is intended to describe a culture. A theme for the architecture builds on the nature of the social goals of the Plan. Structures will rely on stonework, roughhewn wood beams and siding, low overhangs and wide porches. These materials at the turn of the century were the product of individual craftsmen, not mass production. In the same way, early 20th century communities were each small centers for social interaction. Each community was self-sufficient, with its needs being met within walking or horse and buggy distance. Quarter Circle Neighborhood

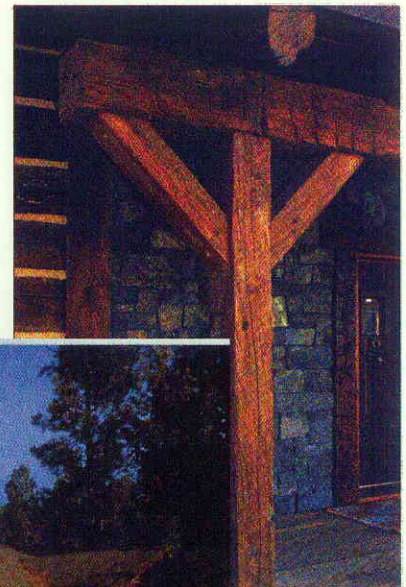

will have the same degree of self-sufficiency and small community social interaction. Though close to Bigfork, the neighborhood will be developed to provide the residents with a very wide variety of services. Fire protection, security, transportation, meals, entertainment and social interaction will be onsite. This is not to say interaction with Bigfork will be discouraged, rather the area will be an extension of the village but will not burden the services of the village. Below are summarized the goals and policies which will be implemented in the ongoing planning process.



- ◆ Protect the southerly view shed of Bigfork
 - Limit thinning on the north slopes visible from Bigfork
 - Manage the timber to encourage a healthy forest
 - Manage the timber using standards more stringent than Best Practices
 - Designate areas for development which are considerate of view sheds and buildings in the horizons
 - Place Conservation easements on appropriate areas

- ◆ Protect the natural resource values of the area
 - Limit development to areas which are most suitable
 - Cluster the residential sites

- Implement strict architectural standards
- Preserve as open space large contiguous areas
- Implement a weed control plan
- Manage the timber to encourage a healthy forest
- Encourage native species to proliferate

- ◆ Encourage neighborhood social interaction
 - Provide a community parking area at the entrance
 - Provide a community transportation service
 - Provide garages and encourages minimal vehicle use. Establish a cart system to service the Lodge, Amenity Areas, Downtown Bigfork, the Post Office and Eagle Bend
 - Provide bike and pedestrian paths
 - Develop a central gathering area at each cluster or neighborhood
 - Manage group social activities
 - Integrate social with recreational activities
 - Implement a recreation-based team building activities

- ◆ Provide a variety of housing choices
 - Adirondacks-themed full service lodge
 - Lodge annexes with efficiency apartments
 - Limited single family home sites
 - Clusters of character cabin sites
 - Clusters of cabin sites
 - Seasonal tent camps
 - Rustic trapper cabin sites

- ◆ Develop a self-sufficient western theme community
 - Build a fire station consistent with the architectural theme
 - Provide onsite modern fire equipment and first aid station

- Offer the fire station as a satellite to Bigfork, or actively manage with trained onsite staff
- Provide common gathering points such as chapel, trapper cabin, and mercantile
- Implement architectural theme for a chateau-style fire lookout/restaurant
- Build community halls for private functions
- Construct public water and sewer facilities to meet infrastructure demands
- Implement the architectural theme in all facilities

2. **COMPLIANCE WITH ADOPTED PLANNING DOCUMENTS**

The initial long-range planning document adopted by Flathead County was the County's 1978 Comprehensive Plan. As with all long range plans, updates are necessary, and that Plan was rewritten in 1987 to address changes in growth patterns, demographics and the local economy. Flathead County adopted, by Resolution 627A, the updated Flathead County Master Plan in 1987. In 1991, concerned citizens in and around the community of Bigfork undertook a lengthy planning process to develop a local land use plan aimed at addressing concerns relative to the rapid and unplanned growth that the Bigfork area was experiencing. The intent of the planning process was to devise a plan that accommodated compatible growth and development in the area, while deterring development that was deemed incompatible with local needs and desires. The community's efforts culminated in the presentation of the Bigfork Area Land Use Plan to the Flathead County Board of Commissioners, who adopted the plan as an amendment to the 1987 Flathead County Master Plan in August of 1993.

The Quarter Circle Neighborhood Plan is essentially a narrative plan for the future use and protection of some 800 acres of undeveloped, privately-held property situated in Flathead County within the Bigfork Area Land Use Plan (BFLUP) planning area. This section of the neighborhood plan contains an evaluation of the policies, goals, objectives and recommendations of both the Flathead County Master Plan and the BFLUP, and demonstrates how the Quarter Circle Neighborhood Plan furthers, adheres to, or meets those aspects of the two documents.

Flathead County Master Plan Compliance

The Flathead County Master Plan addresses the following issues, goals, policies and recommendations in sections of the Plan, all of which will be acknowledged, furthered, adhered to, or met by the proposed neighborhood plan:

SECTION II - LAND USE ELEMENT

Chapter 2 – Rural Communities

ISSUES:

- Rural communities in Flathead County include Lakeside, Somers, Bigfork, Kila, Hungry Horse, Martin City, Coram and West Glacier.
- Rural communities have all existed for from 40-80 years in Flathead County and thus have a history and a heritage.

GOAL:

- Rural service centers which provide an adequate minimum level of urban services, convenience retail

trade, employment opportunities and residential housing sites for the surrounding area while maintaining a semi-rural lifestyle.

POLICIES:

- Promote the growth, development and expansion of rural service centers.
- Encourage the location/expansion of planned residential subdivision in these communities.
- Promote the location and development of centralized commercial service and trade in these communities.
- New commercial activity should be located adjacent to existing commercial development, should be compact in form and should have adequate access and off-street parking.
- Establishment of building setbacks from property lines should be considered for reasons of privacy, fire protection, shading of neighbor's property and to keep buildings from encroaching too close to street rights-of-way.
- Establishment of building height limitations should be considered for fire protection, shading of neighbor's property or blocking of neighborhood views.
- Establishment of limitations on the amount of lot coverage with impervious materials (roofs, asphalt, concrete, etc.) should be considered to limit surface runoff, erosion, and to avoid excessively increasing the density of development.

Through the use of strict architectural control, the clustering of development within the planning area, and the preservation of significant amounts of open space, development within the Quarter Circle Neighborhood will maintain and enhance the historic and cultural heritage of the site, and further all of the above-cited goals and policies of the Rural Communities Section of the Flathead County Growth Policy.

Chapter 4 – Residential Development

POLICIES:

- Residential development should be divided into three groupings: rural residential; urban residential; and high-density, urban residential.
- Rural residential areas provide large lot, estate, ranchette or resort housing opportunities where limited farming/gardening and raising of animals is common and/or privacy, aesthetic considerations and preservation of natural surroundings are paramount.
- Such areas typically do not have either community sewer or water. Private individual wells and septic systems are the norm.
- Development impacts on wildlife should be considered and mitigated whenever development will affect riparian complexes, forested areas over five acres, and marsh areas with or without trees.

The Neighborhood Plan will allow the establishment of resort residential development of the site, completed in a manner

consistent with the policies of the Growth Policy. Clustering residential units will preserve the rural character by retaining significant open space. Clustering will mitigate the impacts of residential development on the wildlife and the natural environment.

Chapter 5 - Commercial / Industrial Development

POLICIES:

- Resort commercial areas should be provided which cater to the tourist, convention goer or traveler.
- Typical resort commercial uses would include hotels/motels, resorts, marinas, incidental commercial activity serving those people using the facility and the immediate area, restaurants, lounges and recreational facilities.
- Resort commercial areas would be expected to occur in close proximity or adjacent to lakes, streams, public open space and recreational areas. Preference should be directed toward the existing rural communities.
- Resort commercial uses should not be located inside residential neighborhoods due to their hours of operation, traffic generation and associated activities.

The Neighborhood Plan will allow resort commercial development consistent with (and an extension of) the historic Flathead Lake Lodge, adjacent to the rural community of Bigfork

Bigfork Area Land Use Plan Compliance

From the vision statement of the BFLUP: “ The Bigfork Planning District encompasses an area with unique natural surroundings that has also become an exceptional cultural center....The neighborliness and community enthusiasm that we now share must be nurtured as part of our social legacy. We believe it to be essential that growth and development within Bigfork and our planning area should be complemented by the preservation of the natural and cultural heritage that we now possess.”

Section I – GENERAL

GOALS:

- Protect the unique natural features and scenic views in the Planning Area through proper siting of development, conservation easements, proper setbacks and creative planning techniques.
- Improve and augment those community attributes that will retain the unique quality and characteristics that enable Bigfork to function as a sought after destination resort village.

Development within the Neighborhood Plan planning area will be respectful of the unique heritage and character of the greater Bigfork area and of the subject property itself. All improvements will be implemented in a manner reflective of existing conditions, rather than by modifying the land to suit the development. The resultant development will be an asset to the community and further solidify its reputation as both a destination resort community and as a special place in which to reside.

Section II – ENVIRONMENTAL

GOALS:

- Encourage use of appropriate timber management practices that respect the value of scenic view sheds, preserve stream habitat and provide continuing wildlife habitat.
- Provide environmentally sensitive open spaces, scenic views and natural habitat in the Planning Area through the use of easements, buffer zones, setbacks and creative planning techniques.

POLICIES:

- Encourage the quality of development that will minimize problems of pollution, erosion, fire, flooding, and hillside damage.
- Regulate land use and setback requirements to preserve agriculture, recreational and natural areas of interest, including wildlife habitat.
- Timber cutting in highly visible areas and along public roadways be required to leave a 100-foot buffer zone of older growth timber.
- Clear cutting be regulated within the Planning Area.

Selective thinning practices have and will continue to be employed on the property, using state-of-the-art, low-impact tree harvesting equipment. The plan calls for significant amounts of open space and the preservation of those qualities of the site that make it unique. Development will be directed to less sensitive

areas which will not increase pollution, erosion, fire threat or other land form damage.

Section IV – Commercial

GOALS:

- Preserve and improve the unique diversity of natural and man made cultural and recreational amenities that provide the Bigfork Planning Area with its unique character and form the foundation of the local economy.
- Encourage landscaping and architectural styling suited to the particular site and area.

The plan will require strict architectural standards with an Adirondack theme, clustering of residences, and extensive revegetation in the limited areas disturbed.

Proposed New Land Use Classification*

The BFLUP contained a specific recommendation for a new, unique classification for the planning area.

VRA Visitor Recreation Area

The principal permitted use is to allow for visitor facilities in both urban and rural areas, that provide commercial recreational uses, characterized by large open spaces with limited building coverage, such as: golf courses, summer camps, equestrian centers, rest areas, etc. The recreational areas are intended as neighborhood gathering sites and may be strewn throughout the open and residential areas. They will be carefully placed and designed to accommodate the mix of uses as they relate to noise, parking, access,

congestion, hours, operation, safety, etc. Housing for support personnel would be located in or near the recreational areas.

** Though not yet created as requested in the BFLUP by the Bigfork Steering Committee, this proposed land use classification embodies the general concept of the proposed neighborhood plan.*

3. ANALYSIS OF STATUTORY CRITERIA

The statutory provisions of MCA 76-1-601 establish the criteria for preparing a Growth Policy Plan. These same statutes are also the criteria for amending such a plan. An application to amend a growth policy plan must contain an inventory of the existing characteristics and features of the jurisdictional area. The lands affected by the proposed amendment are within the planning area governed by the Bigfork Land Use Plan (BFLUP), an amendment to the Flathead County Growth Policy Plan adopted in 1993.

The lands proposed for amendment through the adoption of a specific neighborhood plan are located in the south central area of the Bigfork Area Land Use Plan jurisdiction. Overall, the BFLUP encompasses nearly 46 sections of land, or approximately 29,000 acres. The total area proposed for the neighborhood plan is 800 acres and is shown on Exhibit 1. A neighborhood plan, serving as an amendment to the BFLUP, was chosen as the first step in a lengthy planning and development process. The intent of the neighborhood plan is to (a) clearly identify and state the ways in which the plan acknowledges, furthers, adheres to, and/or meets the issues, goals, objectives and recommendations of the BFLUP, and (b) to define and establish future uses for the subject property.

EXISTING CONDITIONS

Analysis of the existing conditions generally includes the entire BFLUP planning area, with specific emphasis on the community of Bigfork.

Land Uses. The planning area is a unique blend of agricultural, commercial and residential land uses. When the Plan was adopted on August 16th 1993, the primary land use in the area was agricultural. Commercial uses were limited to the intersection of Highways 82 and 35, Highway 35 within the Bigfork community itself, and the downtown area of the Bigfork “village”. Currently, commercial uses exist or are under construction north of the intersection of Highways 82 and 35, south of that intersection, and expanding along the Highway 35 corridor. Conversion of residential and agricultural lands to commercial uses has been limited because the scale and intensity of commercial development can be supported on smaller parcels of land, most of which exist.

The greatest change that the area has experienced is that of residential growth. Since the adoption of the BFLUP in 1993, the County has approved numerous changes to the BFLUP land use map. These changes have converted hundreds of acres from agricultural to residential designations. The zoning classifications adopted pursuant to the land use changes have been primarily residential designations, with lot sizes of less than one half acre. Zoning designations of R-2 and R-3 (One-Family Limited Residential and Two-Family Residential, respectively), have been the norm. The single greatest area of residential growth has occurred in the area of the Eagle Bend recreational community. Approximately 180 acres have been converted from fallow, unused farmland to golf course, marina and residential uses. This change has concentrated population in an area with the necessary infrastructure to provide services. This change is indicative of the character of the growth occurring within the jurisdiction, that being seasonal homes with a recreational focus.

Another significant change in the planning area has been in the number of acres converted from large tract (AG-20 and larger) to small tract (SAG-5) agricultural designations. The net result of this type of land use change has been the loss of open space to scattered, largely unplanned development with increased demands on infrastructure. Impacts to the rural county roads have been particularly significant.

The Quarter Circle Neighborhood Plan is an effort to insure that the Ranch land is dedicated to a well-planned future use that is consistent with the legacy of the Flathead Lake Lodge operation. The mountain area will be characteristic of Bigfork, which is highly amenable to outdoor adventure, water sports, and unique in quality, dining and culture.

Bigfork began the transition from a logging town to tourism with the Flathead Lake Lodge in 1945. The Ranch was a remote vacation destination on the lake and offered outfitting for hunting and fishing in the Bob Marshall Wilderness. Following WWII, the Lodge clientele came from around the world, traveling to Montana by train. After years of family vacations at the Lodge, many guests began a migration to retire in Montana, giving life to single-family residential areas like Eagle Bend and the Lakeshore.

Flathead Lake Lodge continues to offer guests a true "Montana experience", including a complete equestrian, water sports, fly fishing, rafting, and outdoor recreational program. Occupancy is for 120 guests per week, supported by 70 staff members. The emphasis is entirely on family vacations and people interaction. The program has won national acclaim and has been featured in over 80 major publications and television broadcasts. The Lodge earns over a 70% return rate, one of the highest in the United States. Reservations are wait-listed a year in advance, which is indicative of the success of the program. In addition to families,

the ranch has hosted many International and noted events, including U.S. Presidents and dignitaries from 50 countries.

The Lodge has not changed much in concept since Les Averill, who grew up in Somers, started the business in 1945. It has been operated by Doug Averill, the second generation for over 30 years and positioned for the 3rd generation to continue. The Ranch is a hideaway for those seeking simplicity from their public lives. The Ranch has a proven business formula that exemplifies the Montana mystique; a simple concept as popular today as it was 60 years ago.

Flathead Lake Lodge is operated with a purpose. It is dedicated towards the introduction of American families and children to the values and bonds created from a true western adventure, experienced among the natural beauty of Montana.

The Lodge is one of Bigfork's grand benefactors for community fundraisers, benefits, organizations, school functions, meeting host, and community projects. The Averill family helped establish The Bigfork Center for the Performing Arts, The Village Square, The Bigfork Library, Melita Boy Scout Island and many others. It is anticipated that through the expansion of a Mountain Lodge, these community efforts would expand.

The current use of land within the proposed 800-acre neighborhood planning area is entirely agricultural. Agricultural uses are defined as either being cropped or in production. Timber production is the only product-based use on the property. At this time the site is being selectively logged to remove dead and diseased trees. Remaining tree stands will have less density, which will enhance their overall health and growth rate. Improved health and growth means fewer diseased trees and less frequent harvesting.

Lands in the proposed neighborhood plan area are composed of a single 240-acre parcel and multiple 20-acre parcels. The ownership of the 240-acre parcel is separate from the other 560 acres.

Population. Growth in Flathead County has been 2.56% per year, as documented by the last census. Growth in the area served by public sewer and water, more than 4.5% annually, has been nearly twice the County rate for the last five years. This growth is a clear indicator of how attractive the area is to those families searching for either a second home or relocating their primary residence. It should be noted that while population is increasing, local school district enrollment is declining. This is indicative of another demographic – older singles or couples with grown children relocating to the area. Another trend in population demographics in the area is reflected by the number of students in the Swan River School, a school serving the rural Bigfork area with grades K-8. The student population has increased by approximately 30 students in the last four years. An increase in rural school population, in comparison to a decrease in the more urban schools, reflects the fact that there has been significant residential development on scattered lands throughout the jurisdiction.

Housing Needs. Growth is measured by the number of new people documented in the census and number of new water and sewer connections in the local Water and Sewer District. Growth has varied from 2.5% to 7% in the District with an annual average of 4.56%. A large percentage of the growth has been in the Eagle Bend community, which is primarily a second home market. The second greatest area of growth has been in the urban areas of Crestview and O'Brien Terrace. Growth in these areas is documented by utility service applications. The rate of growth does not appear to be slowing, as hook-up applications in the last six months of 2004 exceeded projections by 100%. Another area of housing growth which is more difficult to document is the

demand for short term housing, such as motel or resort accommodations. The only indicator of this housing sector is the 100% bookings at the Flathead Lake Lodge and an increase in seasonal rentals in the Eagle Bend complex.

Economic Conditions. Bigfork's commercial areas are limited to the intersection of Highways 35 and 82, Streeter's Corner, the commercial development near the Highway 83 intersection, strip commercial from the south end of Ice Box Canyon to Highway 209, and downtown Bigfork. The commercial areas primarily serve the BFLUP planning area and seasonal residents. Lake Hills Shopping Center has a grocery store, pharmacy, bank, lounge, hardware and sporting goods store and several small service establishments. All are focused on serving the needs of the residents of the planning area. Downtown Bigfork has a number of upscale restaurants, professional offices, the cultural center, bookstores, art galleries and boutiques. Service population for downtown is more directed to the seasonal and resort resident. In the last 20 years, the seasonal nature of the market has evolved from a May-to-September season to year-round activity. There is a clear decrease in activity in the winter but most stores are open throughout the year, as compared with seasonal openings as recent as 10 years ago. In the last 10 years there has also been an increase in variety as the demands of the planning area change with the changing demographics. Today there are more small specialty boutiques. Economic conditions and growth within the economic sector will continue as long as the residential growth continues in the planning area.

Local Services. In the last ten years the availability of services has increased in the Bigfork area. Today all types of shopping, services and cultural activities are in the community. Service sectors have also improved with a greater variety for the consumer. As an example, where there was a single bank ten years ago, there are now three. Ten years ago, a single dentist served the area;

today there are several. Other opportunities include law firms, restaurants, guest accommodations, galleries and construction services. Eagle Bend was developed as a destination resort. Today Eagle Bend offers 27 holes of golf and a marina accessing Flathead Lake. It is anticipated as the residential base increases, the services available will also increase to meet the demand.

Public Facilities. Public facilities include the elementary, middle and high schools, a fire department, ambulance service, and public water and sewer infrastructure. Recent discussions with the school superintendent indicate all three schools operate at less than full capacity and school populations are declining. At the end of the last school year (June, 2004) there were 294 students in the grade school, 201 in middle school and 350 in the high school. Capacities were reported to be 450, 270 and 400, respectively.

Fire protection is provided by a volunteer fire department. There are 2.5 full-time employees, the fire chief and a fire marshal. Remaining staff are volunteers with approximately 42 active Bigfork Fire & Ambulance members. The Insurance Services Offices rates fire departments based on training, number of volunteers, response time and equipment. One is the highest, and ten the lowest rating awarded. A full-time force is required for a rating above five. Bigfork is rated as a six, the highest for a volunteer department. The site encompassed by the neighborhood plan is not developed. Any fire occurring on the site would be considered a wild lands event. The State of Montana would have jurisdiction for suppressing such a fire, with assistance from the Bigfork department in providing protection for threatened properties.

Police protection is provided by the Flathead County sheriff's office. The neighborhood plan area, undeveloped at this time, does not place a demand for service from the sheriff's office.

Adjoining areas are served by public sewer and water infrastructure provided by the Bigfork County Water and Sewer District. The north and a portion of the west boundary of the neighborhood planning area are common with the District. The lands of the plan are within the future service area of the District. Both the water and sewer facilities are nearing capacity at this time. Because of growth within the District, the District has initiated a planning process to address future needs. A system of plant investment fees is in place to recapture from new users the capital cost of the facilities used. The proposed plan area does not currently require service

Public facilities also include the transportation network serving the area. Two State routes front on the properties: Highways 209 and 35. A third access is provided by roads in The Ranch subdivision situated west of the subject property. A fourth access is also possible through lands owned by Quarter Circle south of the neighborhood planning area, which provides possible access to Highway 35. Potential development of the site is limited to the development standards and density limits of its SAG-5 zoning designation. Densities could exceed one unit per five acres if a Planned Unit Development were approved. Densities in a PUD could be one unit per 2.5 acres. Maximum development would be 320 units. Current volumes and capacities on the major networks are less than capacity. A major reconstruction project is being planned for Highway 35 to address future capacity and safety. When developments are proposed, the traffic impacts are assessed in a mitigation study. The Montana Department of Transportation requires the completion of the needed improvements before approving any approach permits for new developments.

Natural Resources. All of the 800 acres is timbered. Topography is rolling with significant elevation changes to the south and east. The easterly boundary is Forest Service and the State of Montana. Timber production is limited to selective cutting of dead and

diseased and limited mature trees to reduce stand density. Preservation of the understory and reducing the ground disturbance have been the goal of the owners in planning and completing the logging. New equipment with very low ground pressures has been selected for the site to minimize damage. Attached, as Appendix 1, are photos of the logging operations showing the special equipment and processes. Logging has been limited to the southerly 560 acres at this time.

There are no annual or perennial streams in the area.

Wildlife transects the area during the year. Known wildlife on the site include deer, elk and bear. Predators may use the site on occasion. The lands proposed are not significant winter or summer range. Logging which removes a portion of the overstory will encourage increased growth on the forest floor. This may improve the habitat for the deer and elk. There are no known threatened or endangered species associated with the lands. Grizzly bears have been seen in the area but the lands are not identified as part of their normal range.

Ground water may be present in limited amounts. Well logs on file with the Department of Natural Resources indicate well depths on lower lands west of the area of 400 to 450 feet. Production is varied from 50 gallons per minute to less than 10 gpm.

Soils are cobbly silt loams. Surface soils thickness varies based on location. There are numerous areas of cliff and rock outcrops. Soil thickness will vary from a few inches to 10 to 20 feet or more. Soils will be thickest in the valleys and thinnest on the ridges.

The entire site is underlain by the belt super group. Belt series rocks are hard argillities. There are no known minerals associated with these groups.

4. PROJECTED TRENDS

Land Use. Growth in Flathead County and the Bigfork area appears to be continuing. Growth is strong in the seasonal or second home markets. Demand for residential lots will stimulate the development of new subdivisions. The BFLUP encourages the clustering of home sites and preservation of open spaces. Several new projects are in the implementation stages. These are primarily classic single-family residential projects. Bigfork's character is a function of its location, history and people. Bigfork has been and is a recreational resort area. Maintenance of this persona will add to the continuance of its character. The proposed amendment recognizes the uniqueness of the area and provides a land use for continued growth in the recreational resort tradition and to respond to the demand for seasonal housing in a planned environment. Balanced growth will meet market needs for a wide variety of housing and uses.

Population. The most recent statistics for the area estimate growth at 4.56%. If this rate were to continue the population will double in sixteen years. It is apparent from the growth rate that Bigfork is attractive to the people moving to the area. In the past, national economic trends have not altered the economy of the valley. At this time there are no indicators the growth rate will slow. Based on the continued growth, planning in the Bigfork area should anticipate a variety of people with a corresponding demand for a variety of recreation and housing desires.

Housing Needs. Housing needs must be met by a variety of market choices. Families searching for housing may choose a classic single-family detached dwelling, duplex townhouse, apartment or a residence in a planned community. Bigfork has numerous choices from Crestview 80, to Eagle Bend and Harbor Village. Both Eagle Bend and Harbor Village meet the housing needs of a specific group - retirees wishing to reside in the valley

for a part of the year. While the classic single-family projects have proliferated, there have been no planned communities with a distinctive recreational theme since the mid 80's. There is clearly a need within the planning area for a recreational residential area designed to serve the short-term visitor and their recreational needs. The proposed plan amendment addresses this specific group.

Economic Conditions. There are no apparent economic indicators which would lead to a conclusion the current growth in the area will undergo any change in the next few years.

Local Services. The area proposed for the amendment to the Growth Policy will require public water and sewer. Public services are important to allow for clustering and to minimize impacts to the environment. Public water and sewer can be provided by annexation to Bigfork or development of separate public systems. All costs of public infrastructure will be paid by the developer. The school district has been proactive in planning for future needs of the growing population. It has developed the infrastructure in advance of the demand to meet the needs of the residents.

The neighborhood plan establishes the need for a Planned Unit Development and clustering of housing units in the future. Clustering will allow for an increase in density from one unit per five acres to two. The impact of the added service needs will be evaluated in the PUD and subdivision process.

During the future development process, the impacts to the transportation network will be evaluated in detail. Preliminary analysis of the capacities of Highway 35 and 209 indicate normal residential traffic from the neighborhood would not alter the level of service. The Montana Department of Transportation is currently planning an improvement project to increase the capacity of

Highway 35 and to address safety needs. When complete, those new improvements will future traffic demands of the anticipated growth.

The area of the plan amendment has frontage on two state routes 35 and 209. Alternative accesses are possible and would be planned in the ongoing development process.

Natural Resources. Careful stewardship of the resources will preserve their value for future users. Natural resources in the planning jurisdiction are the air, water and land. The BFLUP encourages development, which does not alter the view shed and harmonizes with the topography. Much of the area proposed for the plan amendment is the primary view looking south from Bigfork. A goal of the neighborhood plan is to preserve the views by clustering residential units in sites, which are not directly in view. In the same manner lighting for the recreational components would be subdued and directed downward.

The Swan River, Flathead River and Flathead Lake are very valuable resources in the planning area. Development can affect the water resource through erosion, disposal of poorly treated sewage and storm water runoff. All sewage in the Plan area will be treated in a plant, with the treatment capability to meet the most stringent requirements imposed by the Department of Environmental Quality. Treatment may be in a new onsite plant or by connection to an existing facility, such as Bigfork.

There are no springs or surface water on the site proposed for the Amendment. Rules of the DEQ establish the provisions for erosion control and storm water collection and treatment. Compliance with these rules will protect the natural resources of the planning area and area proposed for amendment.

Timber is the only natural resource with extractive value on the site. In the past, much of the lands with timber in the planning area have been harvested using traditional methods. Land disturbance is significant with traditional equipment such as skidders, cats and line logging. Current harvest methods implemented on the subject lands emphasize low ground pressure equipment and harvest of dead and diseased timber while the healthy trees remain for future harvest, ground cover and wildlife habitat value. Photos of the equipment are enclosed in the appendices.

Another component of the land is open space. Development with unimaginative lot layouts with classic zoning consumes large areas per lot, when the actual house and accessory structures may cover only a half acre. The waste is in unneeded roads, driveways, parking and expanses of lawn. The neighborhood plan proposes residential units clustered in groups with significant open space separating the various neighborhoods. This is a wise use of the land. Land forms, such as cliffs, hillsides and grassy valleys are also resources. Clustering allows much of these types of areas to remain undisturbed.

Implementation. The existing regulatory structure, the growth policy, zoning ordinance and subdivision rules provide the structure to assure compliance with the goals and policies of the Growth Policy and Bigfork Land Use Plan. As the planning for the site proceeds from a Growth Policy Amendment to the Planned Unit Development and subdivision, each process will require greater detail. After an amendment to the Growth Policy is approved, the following step is the PUD and subdivision. Each process will include opportunities for public input and comment. Implementation can be a lengthy process consuming six to nine months.

Development Infrastructure. As the project proceeds through the development sequence, the infrastructure needs to serve a

development will be defined. Water and sewer service may be provided by the Bigfork County Water and Sewer District after the lands were annexed or by other public systems. All infrastructure would be installed to state standards by the developer. Operation and maintenance would be the owner's responsibility. Access is from two State Highways. A Traffic Mitigation Impact Study may be needed before the Department issues the approach permits. On site road improvements would be constructed to Flathead County Standards. Again, costs of road construction would be borne by the developer. Long-term maintenance would be provided through the development's road users association. Storm water collection and treatment must conform to the standards adopted by the State Department of Environmental Quality. Construction of the improvements would be the responsibility of the developer. Maintenance would be the responsibility of the Owners Association. The nearest solid waste collection site is in Creston or west of the site along Highway 82. Individual owners have the responsibility to haul their solid waste to a collection site or contract with a hauler to collect and transport the waste to the central landfill. When the intensity of development is defined, the impacts of the waste can be assessed. Currently each lot and tract in the County pays a fee for disposal. The disposal fee is assessed to recover the cost of operating the landfill. If there are other costs, they will be evaluated in the ongoing process. Fire protection is provided by the volunteer fire department. During the development process the Department would be consulted on road grades, cul de sac lengths and fire hydrant placement. The lands in the area will pay taxes, a portion of which support the fire department.

Schedule. The defined element in the process is the Growth Policy Amendment. Next steps are preparation and submittal of the Planned Unit Development and Subdivision. In the schedule presented below we have shown the dates for the various actions

for the Amendment and indicated a time frame for the other activities.

Application to Amend the Growth Policy	May 31, 2005
Meeting with BF Land Use Advisory	June 23, 2005
Planning Board Public Hearing	July 13, 2005
Commissioners' Resolution of Intent to Amend	Aug. 3, 2005
Publish Notice of Intent	Sept. 7, 2005
Commissioners' Final Resolution	Sept. 7, 2005

Conclusion. The process initiated with this application will amend the Growth Policy Plan to define the uses and area for the Quarter Circle Neighborhood. Approval of the Amendment allows the planning needed to prepare a detailed Planned Unit Development application and subdivision to begin, with the certainty the lands are useable for the intended uses. Approval does not bestow upon the applicant a right to develop. It provides a basis for the applicant to bring forward an application requesting other approvals for development.

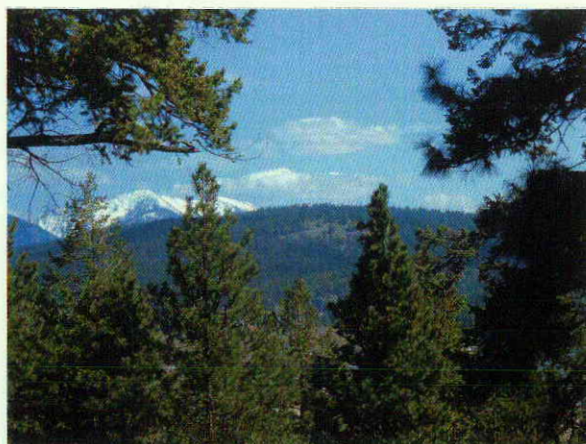

J:\general-promo-future\averill-saddle\K04-018-exhibitA.dwg, 5/31/2005 11:14:38 AM, DJK,TDH Kallispell

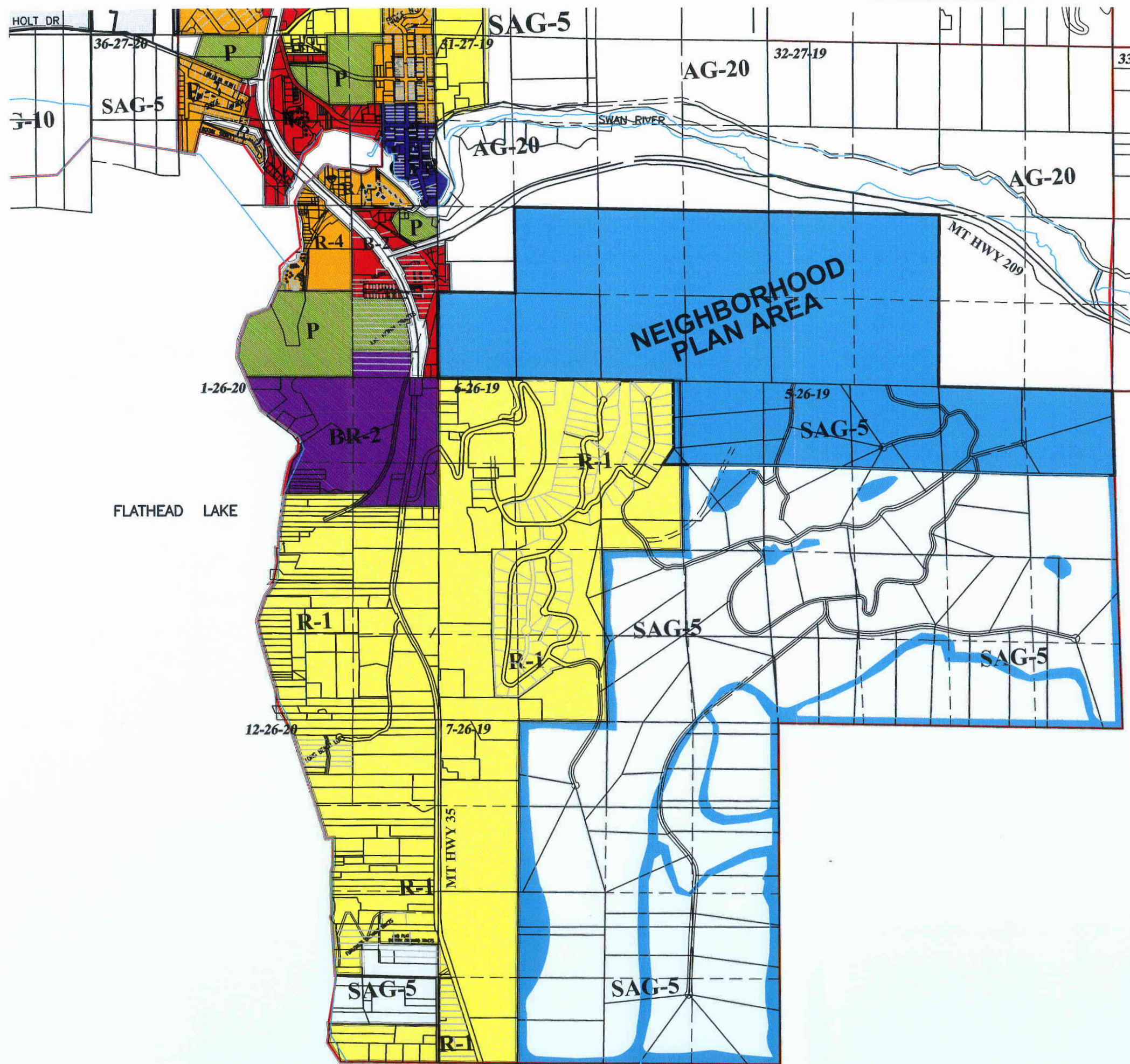

LEGEND

- C Commercial
- RC Resort Commercial
- CCC Commercial Country Corner
- CVR Commercial Village Resort
- IL Light Industrial
- UR Urban Residential
- SR Suburban Residential
- P Public
- AG Agricultural Lands
- Area of Transition

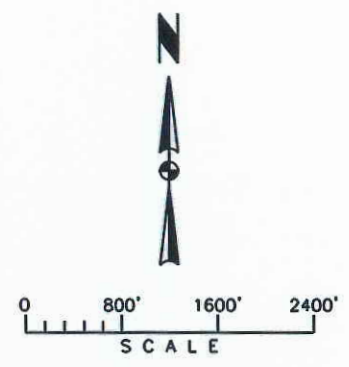

REVISIONS

DATE	DESCR

THOMAS, DEAN & HOSKINS, INC.
 ENGINEERING CONSULTANTS
 GREAT FALLS - BOZEMAN - KALISPELL - HELENA
 SPOKANE - LEWISTON
 MONTANA
 WASHINGTON
 IDAHO

DRAWN BY: SMS
 DESIGNED BY:
 QUALITY CHECK:
 DATE: 3/15/04
 JOB NO. K04-018
 FIELDBOOK

QUARTER CIRCLE
 FLATHEAD COUNTY, MONTANA
 LAND USE
 FIGURE 1

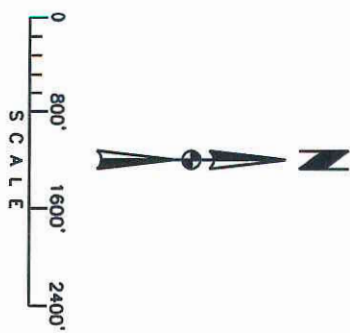
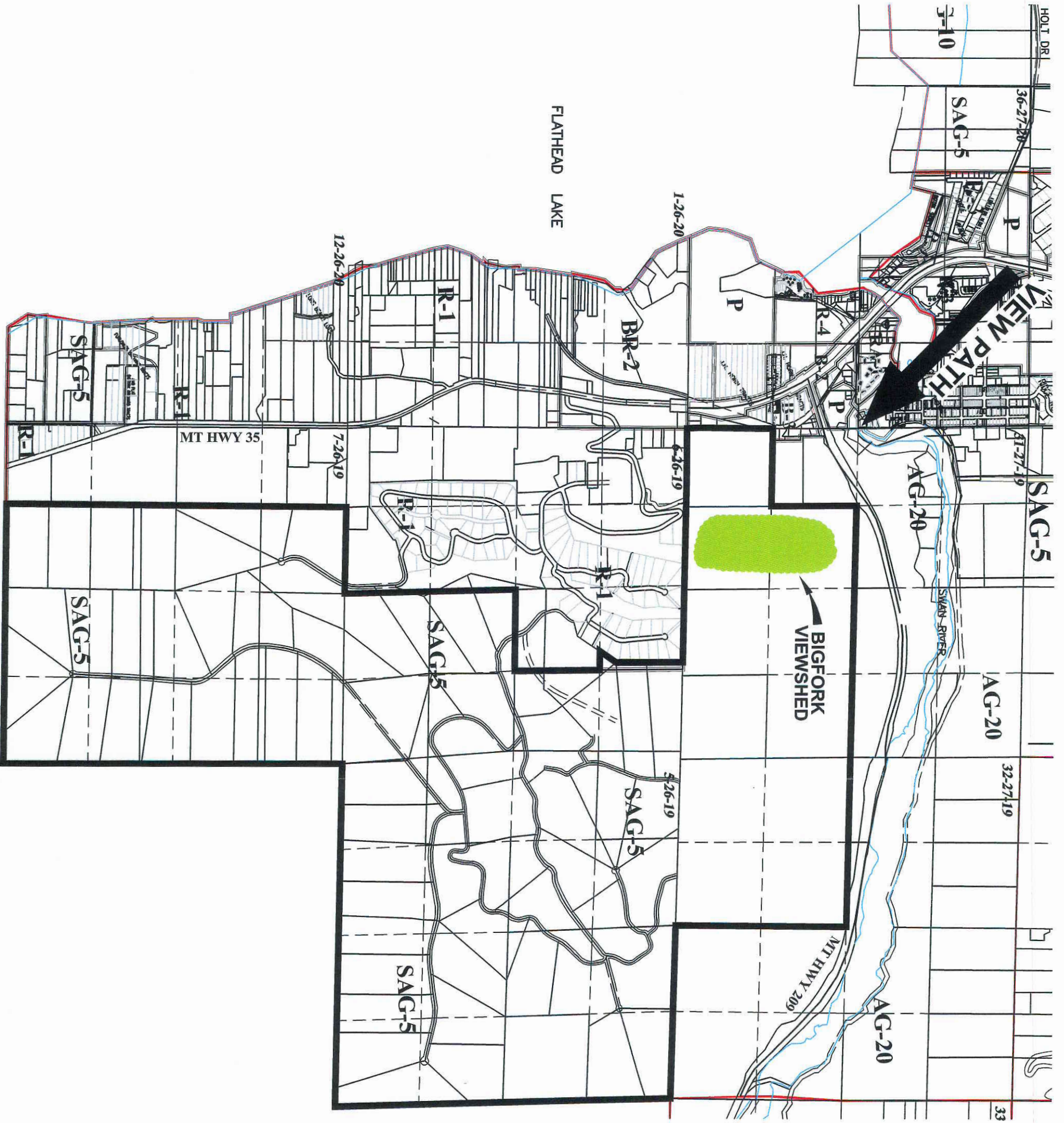

QUARTER CIRCLE
FLATHEAD COUNTY, MONTANA

BIGFORK VIEWSHED
FIGURE 2

DRAWN BY: SMS
DESIGNED BY:
QUALITY CHECK:
DATE: 3/15/04
JOB NO. K04-018
FIELDBOOK

REVISIONS		
BY	DATE	DESCR
BY	DATE	DESCR
BY	DATE	DESCR



THOMAS, DEAN & HOSKINS, INC.
ENGINEERING CONSULTANTS
GREAT FALLS - BOZEMAN - KALISPELL - HELENA
SPOKANE
LEWISTON
MONTANA
WASHINGTON
IDAHO

J:\general-promo-future\averrill-saddle\zoning.dwg, 5/31/2005 11:29:41 AM, DJK,TDH,Kalispell

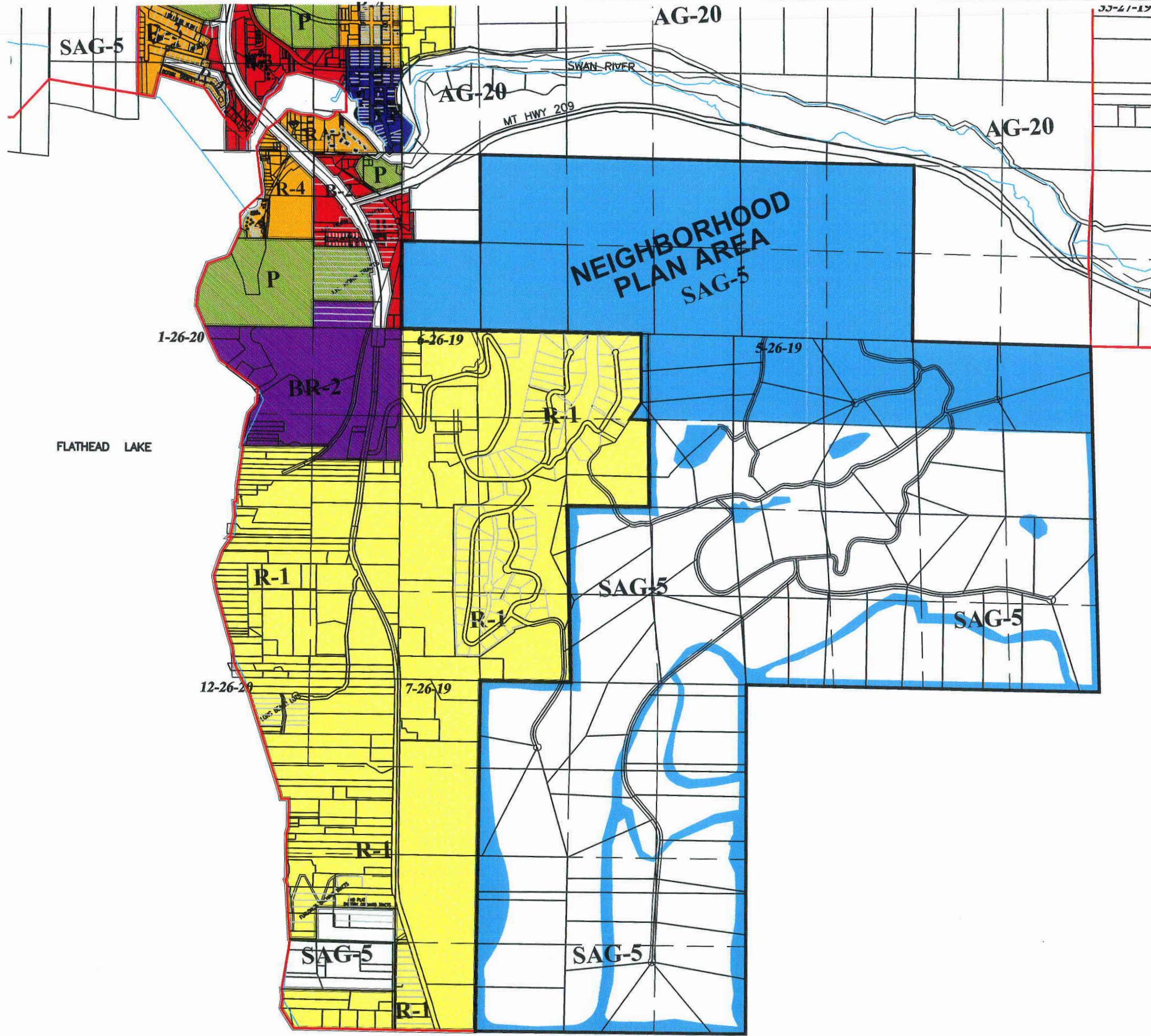

LEGEND

- C Commercial
- RC Resort Commercial
- CCC Commercial Country Corner
- CVR Commercial Village Resort
- IL Light Industrial
- UR Urban Residential
- SR Suburban Residential
- P Public
- AG Agricultural Lands
- Area of Transition

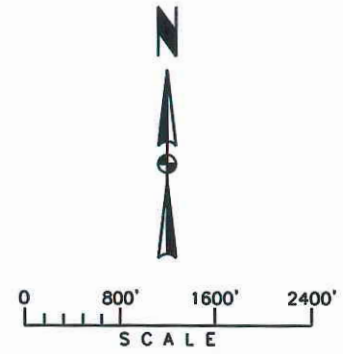

REVISIONS	
DATE	DESCR

BY: _____
 DATE: _____
 BY: _____
 DATE: _____
 BY: _____
 DATE: _____

THOMAS, DEAN & HOSKINS, INC.
 ENGINEERING CONSULTANTS
 GREAT FALLS-BOZEMAN-KALISPELL-HELENA
 SPOKANE-LEWISTON
 MONTANA
 WASHINGTON
 IDAHO

DRAWN BY: SMS
 DESIGNED BY:
 QUALITY CHECK:
 DATE: 3/15/04
 JOB NO. K04-018
 FIELDBOOK

QUARTER CIRCLE
 FLATHEAD COUNTY, MONTANA
 LAND USE & ZONING
 FIGURE 3

J:\general-promo-future\averill-saddle\K04-018-exhibitA.dwg, 5/31/2005 11:26:08 AM, DJK,TDH Kalispell

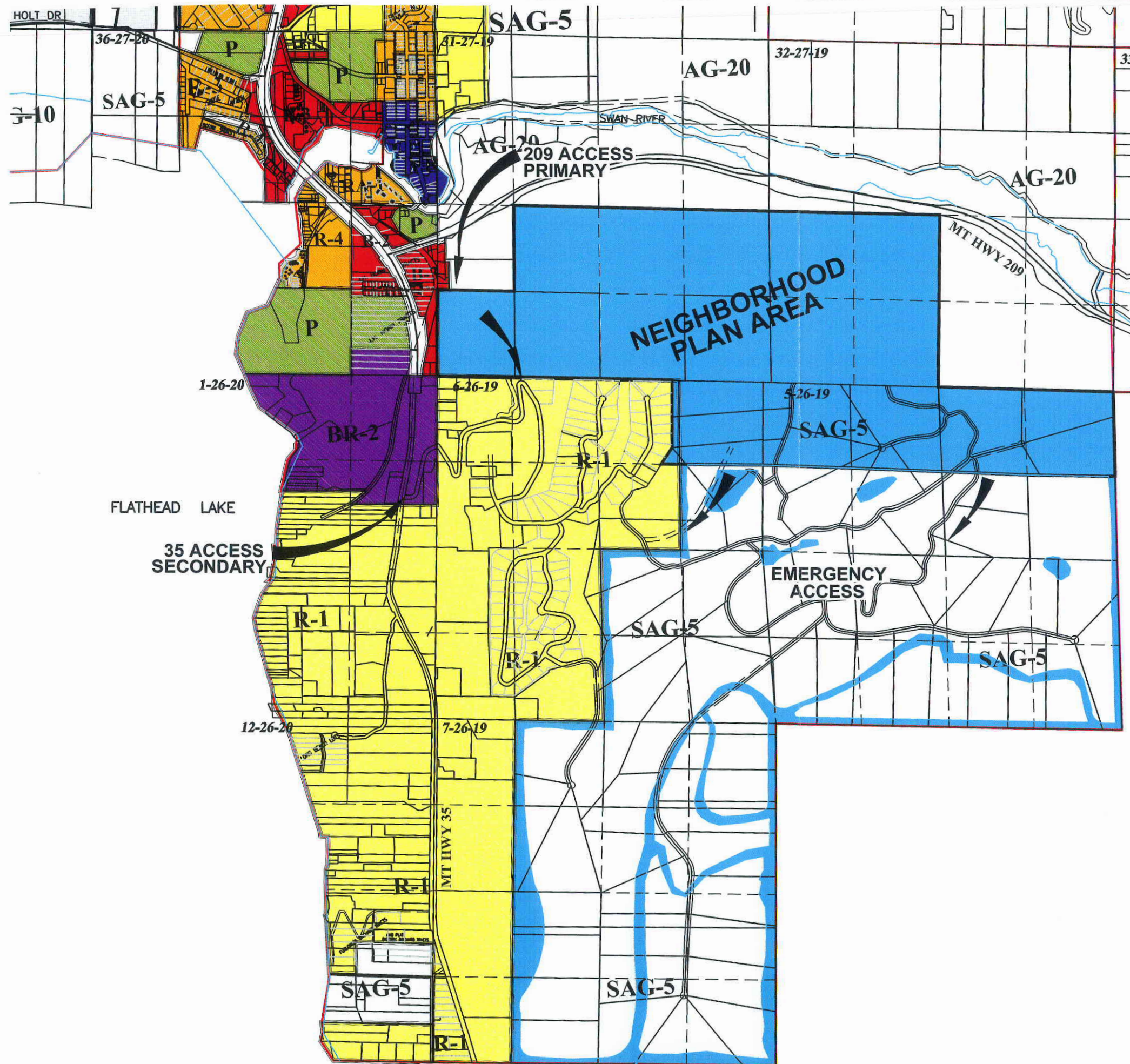

LEGEND

- C Commercial
- RC Resort Commercial
- CCC Commercial Country Corner
- CVR Commercial Village Resort
- IL Light Industrial
- UR Urban Residential
- SR Suburban Residential
- P Public
- AG Agricultural Lands
- Area of Transition

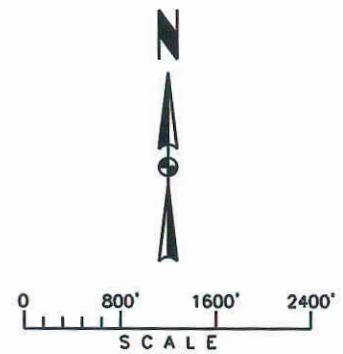

REVISIONS	
DATE	DESCR

DRAWN BY: SMS
 DESIGNED BY:
 QUALITY CHECK:
 DATE: 3/15/04
 JOB NO. K04-018
 FIELDBOOK

TD&H
 THOMAS, DEAN & HOSKINS, INC.
 ENGINEERING CONSULTANTS
 GREAT FALLS-BOZEMAN-KALISPELL-HELENA
 SPOKANE WASHINGTON LEWISTON MONTANA IDAHO

QUARTER CIRCLE
 FLATHEAD COUNTY, MONTANA
 ACCESS POINTS
 FIGURE 4